

Produktreparatur/-einstellung

OC 3300 - OC 3400 - RC 4030 - RC 4045 - RC 4060 - RC 4100 - RC 4130
- RC 4300 - RC 4350 - RC 4360 - RC 4370 - RC 4380 - RC 4400 - RC 4401 -
RC 4402 - RC CA 43 - RX 4350 - RX 4450

Zusammen bauen des Reinigers



- Steuerbox vor jedem Eingriff vom Stromnetz trennen.

1

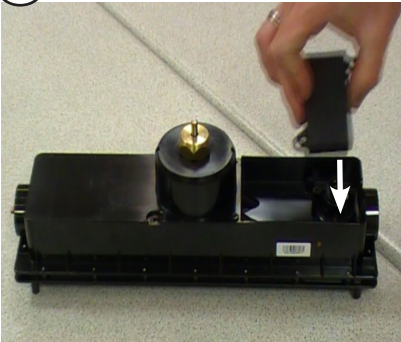

2

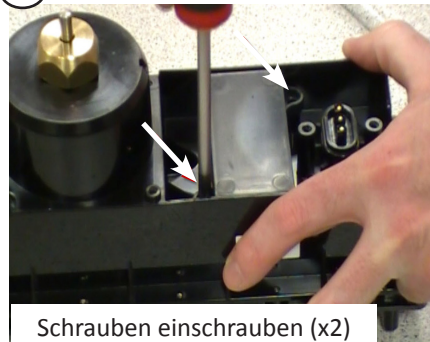

3



4



5

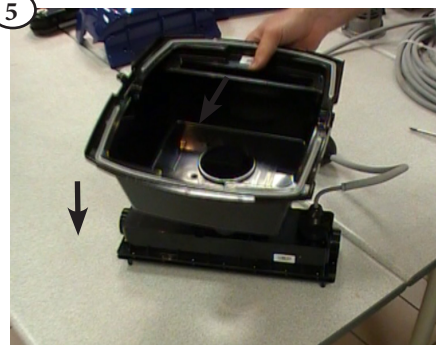

6



7



8



Bevor die Kassette festgeschraubt wird, muss das Kabel ordnungsgemäß befestigt werden (siehe nächster Schritt)

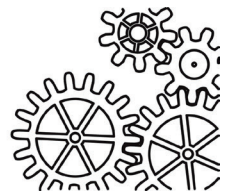

- Befestigung des Kabels: Richten Sie sich je nach Version des Kabels und des Reinigers nach der untenstehenden Abbildung **A**, **B** oder **C**.
- In allen 3 Fällen achten Sie auf einen Überstand des Schwimmkanals um 5 mm: siehe Abbildung **D**.

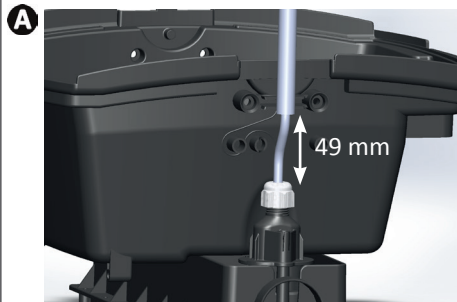

A Altes Kabel (Länge des abisolierten Kabels: 49 mm)
=> Das Kabel darf nicht an den Fixierungen befestigt werden

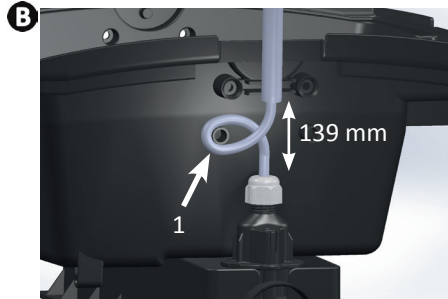

B Neues Kabel (Länge des abisolierten Kabels: 139 mm)
=> Das abisolierte Kabel an **einer Fixierung** befestigen

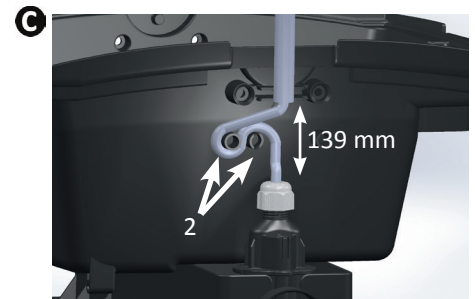

C Neues Kabel (Länge des abisolierten Kabels: 139 mm)
=> Das abisolierte Kabel an **zwei Fixierungen** befestigen

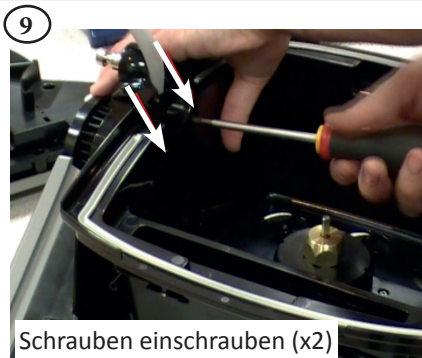
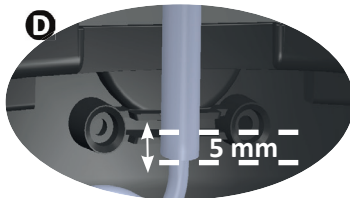

9 Schrauben einschrauben (x2)

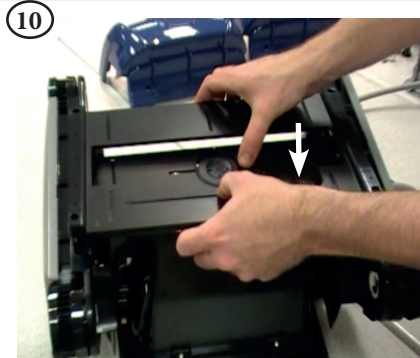

13 Schrauben einschrauben (x2)



11 Schrauben einschrauben (x4)

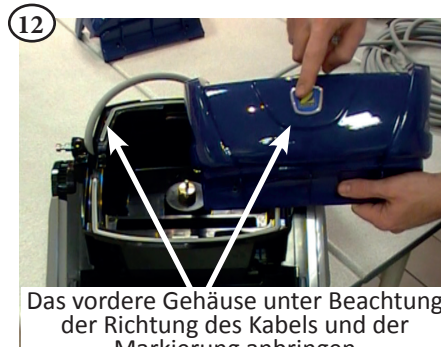

12 Das vordere Gehäuse unter Beachtung der Richtung des Kabels und der Markierung anbringen

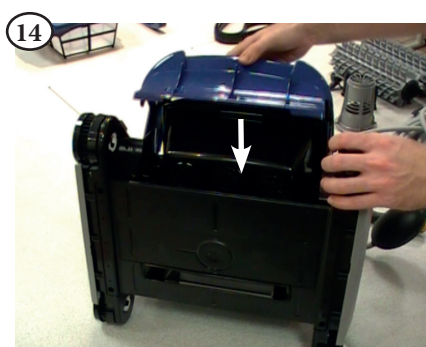

15 Schrauben einschrauben (x2)



16 Den Propeller wieder anbringen

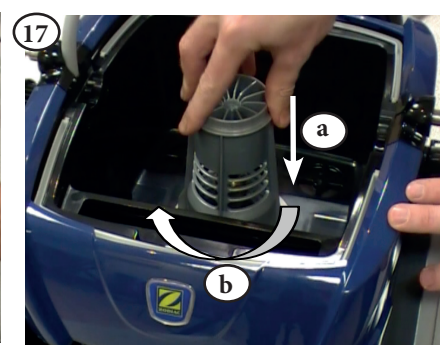

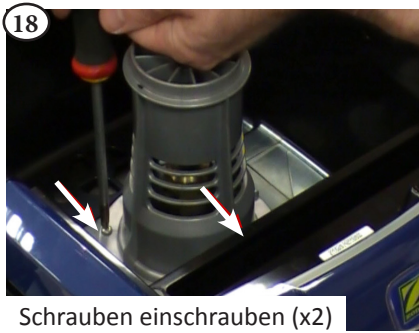

Schrauben einschrauben (x2)

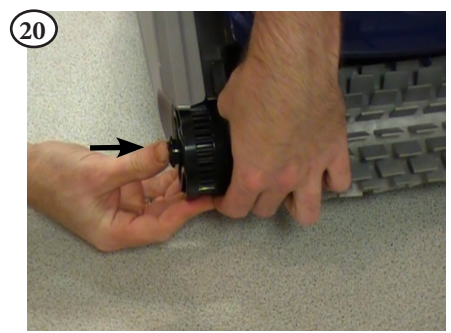
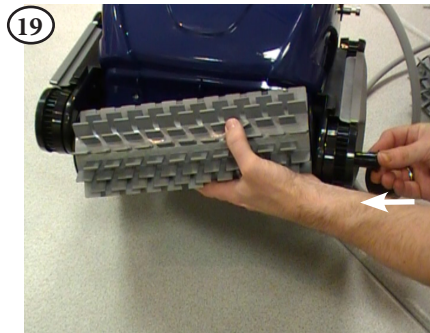

Die Raupenbänder anbringen



Das Raupenband unter die 2 Führungen legen



Schraube einschrauben (x1)



Schraube einschrauben (x1)

